

Datasheet Actuator: *Curve*® plugged 3940E20

- Active length: **39 mm**
- Module size: **59 mm x 40 mm x 2.5 mm**
- Bending: **medium (E20)**
- Weight: **6.4 g + hosting structure**
- Hosting structure: **steel + rivets, tip 25 mm**
size 94 x 40 x 0.45 mm³
- Load range with high cycling stability (> 300.000)
 - at module edge: **1420 g**
 - at 25 mm: **940 g**
 - at 50 mm: **700 g**

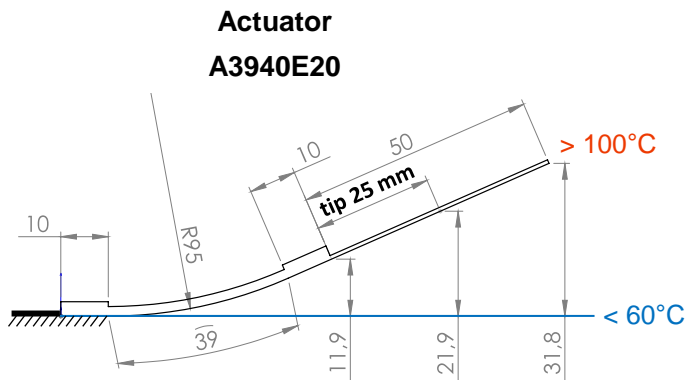

M3940E20 – Actuator Module only

- Operating mode: **plugged**
- Thermal activation by: **resistive heating**
- Electronic circuit: **all wires in series**
- Resistivity: **1.6 Ohm**
- Full Activation (DC): **e.g. 3 A for 15 s / 4 A for 4 / 5 A for 1.3 s**

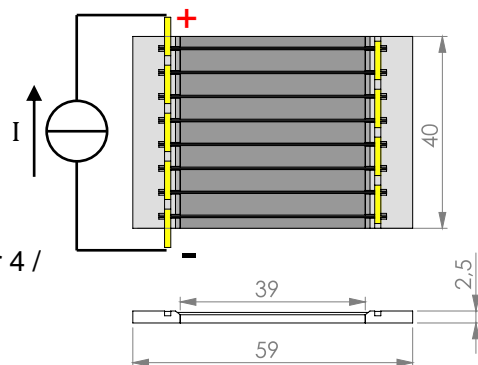

© CompActive GmbH

All values are only estimations!

Customized, high-performance actuators by ...

... high-tech solutions

- reliable load transfer
- proven cycle stability
- injection molded frame elements
- special SMA material specifications
- high temperature FRP
- self-sensing capability



actuator test bench

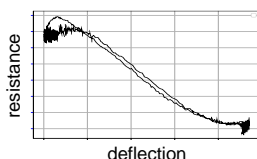

deflection

... customized mechanical fixation

- adhesive films
- liquid adhesives
- bolts, rivets, screws
- plug-on

... individual design

- substrate (metals, polymers)
- size
- deflection
- load / cycles
- wire material / temperatures
- electrical resistance

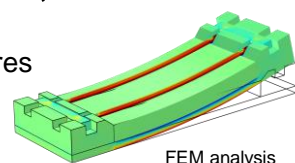
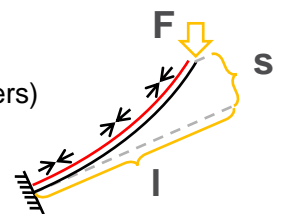

FEM analysis

... various electrical connection

- crimping
- soldering
- plugging in
- welding



© CompActive GmbH